



SPX Air Treatment

High-Volume Refrigerated Compressed Air Dryers

PNC Series & ESR Series



PNC Series & ESR Series High-Volume Refrigerated Air Dryers

Pneumatic Products Refrigerated Dryers Improve Productivity

Pneumatic Products has designed and manufactured energy-efficient solutions for compressed air treatment since 1946. People around the globe rely on Pneumatic Products to deliver the best solutions to improve compressed air quality and reduce operating costs. Properly treated compressed air eliminates product rejects or spoilage, caused by moisture, solids and oils, all byproducts of the air compression process.

Improved Operations

Liquid water in a compressed air stream increases the cost of operation. Product rejects mount and countless hours are wasted on unscheduled maintenance. Highly acidic, condensed water corrodes air motors and valves and, damages finished goods on contact.

Low Cost Solution

Refrigerated dryers are a wise investment. With low initial cost and low cost of operation, they pay dividends for many years to come. Refrigerated drying technologies excel where the ambient temperature remains higher than the pressure dew point. Ideal candidates for this technology are most indoor, climate-controlled areas, where temperatures comfortable to people are maintained.

ISO 8573.1 Air Quality Standards

Class	Solid Particles, (d μm)			Pressure Dew Point		Oil, Aerosol, Liquid Vapor	
	0.10 < d ≤ 0.5	0.5 < d ≤ 1.0	1.0 < d ≤ 5.0	°C	°F	mg/m ³	ppm w/w
0	As Specified			As Specified		As Specified	
1	100	1	0	≤ -70	-94	≤ 0.01	0.008
2	100,000	1,000	10	≤ -40	-40	≤ 0.1	0.08
3		10,000	500	≤ -20	-4	≤ 1	0.8
4			1,000	≤ +3	38	≤ 5	4
5			20,000	≤ +7	45	> 5	> 4
6				≤ +10	50		
				Liquid Water g/m ³			
7				C _w ≤ 0.5			
8				0.5 < C _w ≤ 5			
9				5 < C _w ≤ 10			

Per ISO 8573-1: 2001(E)

How Much Condensate Can There be?

At an ambient of 75°F and 75% relative humidity, a typical 1,000 HP (5,000 scfm) air compressor inhales 900 gallons of water vapor every 24 hours. Discharging air at 100°F and 100 psig, a well-maintained aftercooler may remove about 570 gallons. That leaves you with 330 gallons left inside your air system. At the CAGI ADF100 standard of 38°F pressure dew point (ISO 8573.1 Class 4), a refrigerated dryer removes an additional 290 gallons. The remaining 40 gallons safely pass through the system as water vapor

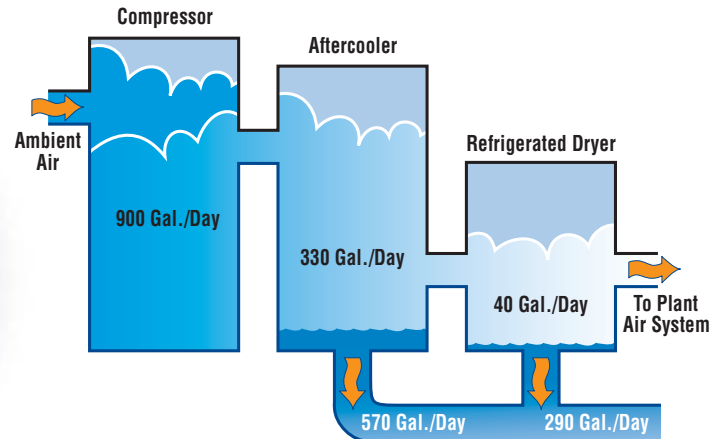

**Pneumatic Products...
Quality High-Volume Refrigerated Dryers**

Pneumatic Products crafts high-volume dryers by leveraging two distinct designs to satisfy the requirements of large air users. Each open-frame, high-capacity style refrigerated dryer is engineered to match the specific air demands of your compressed air system.

**PNC Series - Non Cycling Dryers
4,000 thru 20,000 scfm**

PNC Series high-volume, "Premier Non-Cycling" dryers combine economy and performance. Dry compressed air and energy savings result from traditional non-cycling refrigeration systems incorporated into a space saving design. PNC Series dryers feature:

- Continuous-duty refrigeration systems for reliable 38°F dew points
- Integral head-unloaders save energy during times of reduced air demand
- Integral Filtration removes contaminants to 3 micron

**ESR Series - Cycling Dryers
4,000 thru 12,000 scfm**

ESR Series "Energy Saving Refrigerated" cycling dryers automatically match energy savings to your air demands. A simple refrigeration system chills a large volume of thermal storage fluid that possesses exceptional heat transfer characteristics. Much like your refrigerator at home, we start-and-stop the refrigeration compressor as needed. Cold thermal storage fluid circulates continuously through durable shell type heat exchangers and around the all copper tubes to provide 33°F - 39°F pressure dew points. ESR Series dryers feature:

- Energy efficient cycling operation to match energy savings to plant air demands
- Text display delivers Percentage-of-Energy savings, Process Control Temperature, Preset or Adjustable Dew Point value.
- Pneumatic No-Air-Loss demand drains, are included as standard



PNC Series - Non-Cycling Dryers 4,000 thru 20,000 scfm

Performance, Economy and Value

PNC Series refrigerated air dryers deliver economical operation and competitive pricing through traditional non-cycling technology. Continuous-duty operations, are ideal candidates for these precision engineered dryers. Simplicity and dependability provide large volume compressed air users with maximum value in terms of initial purchase price and cost of operation. Environmentally friendly refrigerants deliver consistent 38°F pressure dew point performance to protect your critical, pneumatically powered operations.

Controlled Compression Ratio Advantage

The cold energy is harnessed through a combination of carefully selected components and the compressor runs continuously. Energy saving unloaders control the compression ratio inside the cylinders to adapt to air demand. Energy savings of up to 67% result under part load conditions. State-of-the-art logic controls manage the process.

Controlled Compression Energy Savings Vs. Load

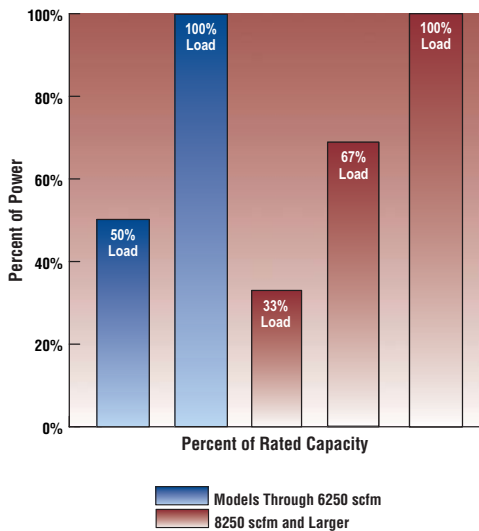

How it Works

Refrigerant is compressed and circulated through the refrigeration system. Evaporator temperature sensors control the operation of a dependable Hot Gas Bypass Valve (HGBV) and a Thermal Expansion Valve (TEV) to deliver stable dew points. In conjunction with capacity unloaders on the compressor, fully automatic and energy efficient operation is achieved. Potential for freeze-ups are eliminated.

Saturated incoming compressed air is quickly chilled in the air-to-air heat exchanger (A) by the cold compressed air as it

exits the evaporator (B). Here, the cold, dry air is reheated to prevent pipeline sweating and reduce compressor energy before exiting the dryer. Next, automatic drain (C1) removes the condensate. In the evaporator, the air temperature is reduced to that of the cold refrigerant, where a second automatic drain (C2) removes moisture. A separator/filter lowers the velocity, mechanically separates the condensate from the air stream, and captures the particulate matter. A third automatic drain (C3) removes the condensate. The air-to-air heat exchanger re-heats the air and clean, dry compressed air exits the dryer.

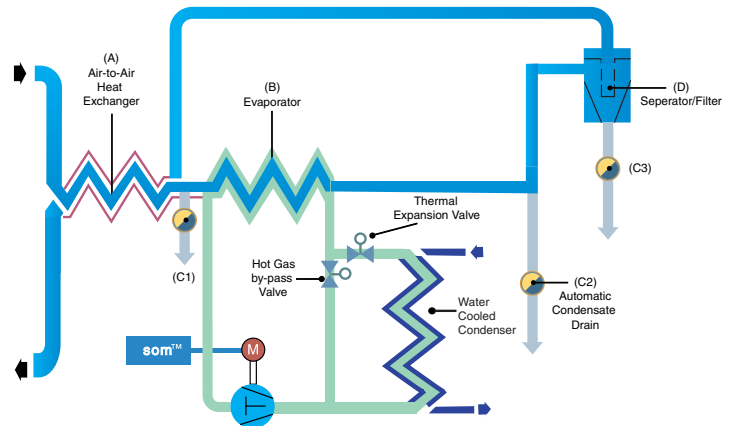

System Operation Monitor (SOM)

The SOM control panel measures and displays critical air and refrigerant temperatures, signals operating conditions which may affect performance, and enables panel adjustment of the automatic drain valve.

System Operation Monitor delivers:

- Alphanumeric backlit LCD text display and Operating Status LEDs.
- Membrane touch-panel with selectable text display for critical air and refrigerant temperatures
- System circuit diagram with advisory LEDs for temperature normalities



PNC Series - Product Features

			System Operation Monitor Control Panel					Integral Filtration			Refrigeration Control Valves		Refrigerant	
On & Off Switch	Power on LED	Dew Point Temp. Indicator	Backlit LCD Alphanumeric Text Window	Normal Operation LED	Check Operating Conditions LED	Service is Due LED	System Alarm LED w/ Remote Dry Alarm Contacts	Integral Filtration Removes Dirt, Water & Lubricant	Time Adjustable Condensate Drain Valves	Pneumatic No-Air-Loss Demand Drains	Temp. Indicator	Hot Gas Bypass	Thermal Expansion	CFC-Free
S	S	S	S	S	S	S	S	S	S	0	S	S	S	S
S=Standard O=Option														

Central Controls

Inlet/Outlet Air Pressure Gauges & Easily Accessible Refrigeration Circuit Controls

Automatic Energy Savings

Continuous-duty, semi-hermetic compressors include energy saving capacity unloaders

Integral Contaminant Removal as Standard

Two-stage separator features coalescing elements designed to remove 99+% of condensed moisture, solids to 3 micron

Automatic Moisture Removal

Three (3) Automatic time-actuated solenoid valves are standard. Upgrade to Pneumatic demand drains to maximize energy efficiency. (Not Shown)

38°F Dew Points and Low Pressure Drop

Non-fouling, smooth copper tubes, and shell type heat exchangers, deliver 38°F dew points and low pressure drop.

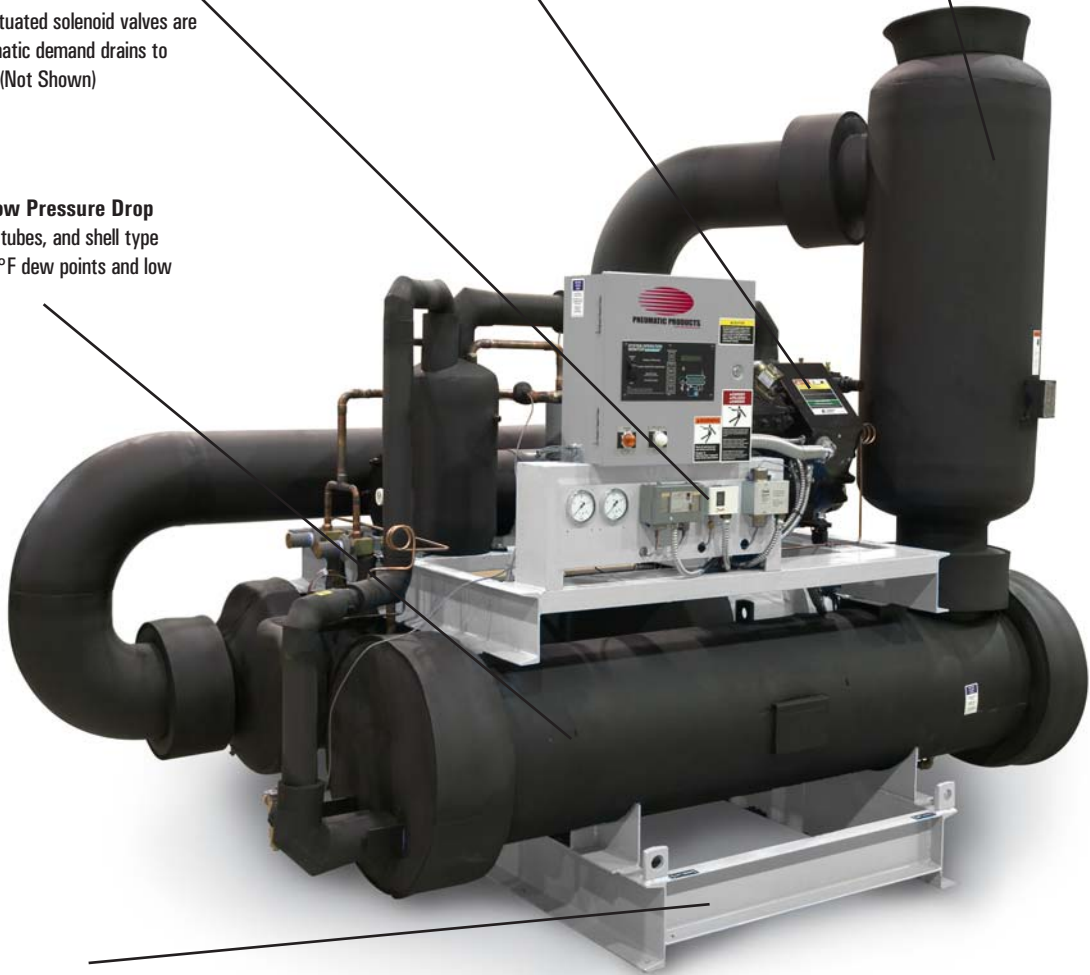

Small Footprint

Streamlined packaging requires minimal floor space

ESR Series - Cycling Dryers 4,000 thru 12,000 scfm

Performance, Energy Savings, Returns-on-Investment

Pneumatic Products energy saving "cycling" type refrigerated dryers leverage technology that has served generations of compressed air users. Energy savings mirror plant air demands to maintain a 33°F - 39°F range of dew point integrity. High-capacity, ESR Series "Energy Saving Refrigerated" cycling dryers, proudly carry on the Pneumatic Products tradition of delivering reliability, consistent dew point control and, clean, dry compressed air. Pay the absolute minimum for electricity to realize fast returns-on-investment.

Thermal Fluid Storage System Advantage

High Capacity ESR Series dryers use a Thermal Fluid Storage system to save energy. Cold energy is stored and released as needed to offer tremendous energy savings under part-load conditions. Operational simplicity is similar to your home refrigerator. The refrigeration compressor is turned "on" and "off" (cycled), to match the actual air demand in your facility. Savings on electricity are provided in linear proportion to air demands.

Thermal Fluid Storage Energy Savings

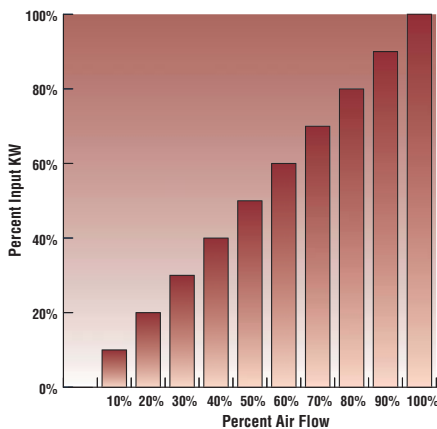

How it Works

Environmentally friendly NO CFC refrigerant is compressed and circulated through the refrigeration system. Cold liquid energy is transferred from the refrigerant to the thermal fluid in the Thermal Fluid Storage heat exchanger. Here, the large volume of thermal fluid is prepared and controlled. Temperature sensing thermocouple outputs are used to turn the refrigeration compressor on or off to maintain a 1°F hysteresis. A small pump circulates the cold thermal fluid in a loop.

Saturated incoming compressed air is quickly chilled in the air-to-air heat exchanger (A) by the cold compressed air as it exits the evaporator (B). Here, the cold, dry air is reheated to

prevent pipeline sweating and reduce compressor energy before exiting the dryer. Next, an automatic drain (C1) removes the condensate. In the evaporator, the air temperature is reduced to that of the cold thermal fluid delivered from thermal fluid storage (D). Finally, moisture separator (E) lowers the velocity and mechanically separates the condensate from the air stream. A second automatic drain (C2) removes the condensate. The air-to-air heat exchanger re-heats the air and clean, dry compressed air exits the dryer.

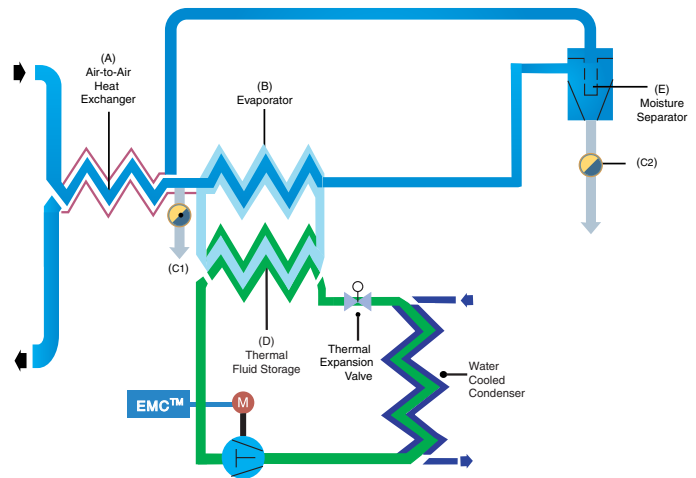

Energy Management Controller (EMC)

The EMC delivers a wealth of control and system monitoring capabilities. EMC can inform you of system operating status, reinforce your decision to purchase an ESR Series dryer with actual energy savings displayed or, even advise you of trouble with warnings/alarms.

EMC features include:

- Power-off timer (counts and displays the seconds without power)
- Auto restart/Warm up timer (energizes crankcase heater then, calculates and displays minutes-until-restart once power is restored)
- Cumulative run-time/compressor-on time recording (includes cumulative time reset function to help track maintenance intervals)



ESR Series - Product Features

Operational Status LEDs					Digital Alphanumeric LCD Text Display & Item Selected LED				Drain	Refrigerant
On & Off Membrane switches	Power on LED	Automatic Restart After Power Loss LED	Fahrenheit & Celsius Temp. LEDs	High & Low Temp. LEDs	Process Control	Preset Dew Point Selected	Adjustable Dew Point Selected	Percent of Energy Savings	Pneumatic No-Air-Loss Demand Drains	CFC-Free
S	S	S	S	S	S	S	S	S	S	S

S=Standard O=Option

Thermal Fluid Storage

Cold energy is stored and released as needed to save energy

Energy Saving EMC Controller

Text display delivers Percentage-of-Energy savings, Process Control Temperature, Preset or Adjustable Dew Point value, and more

Superior Moisture Removal

Mechanical separator designed to remove 99+ % of condensed moisture. Pneumatic demand drains are standard to maximize energy efficiency.

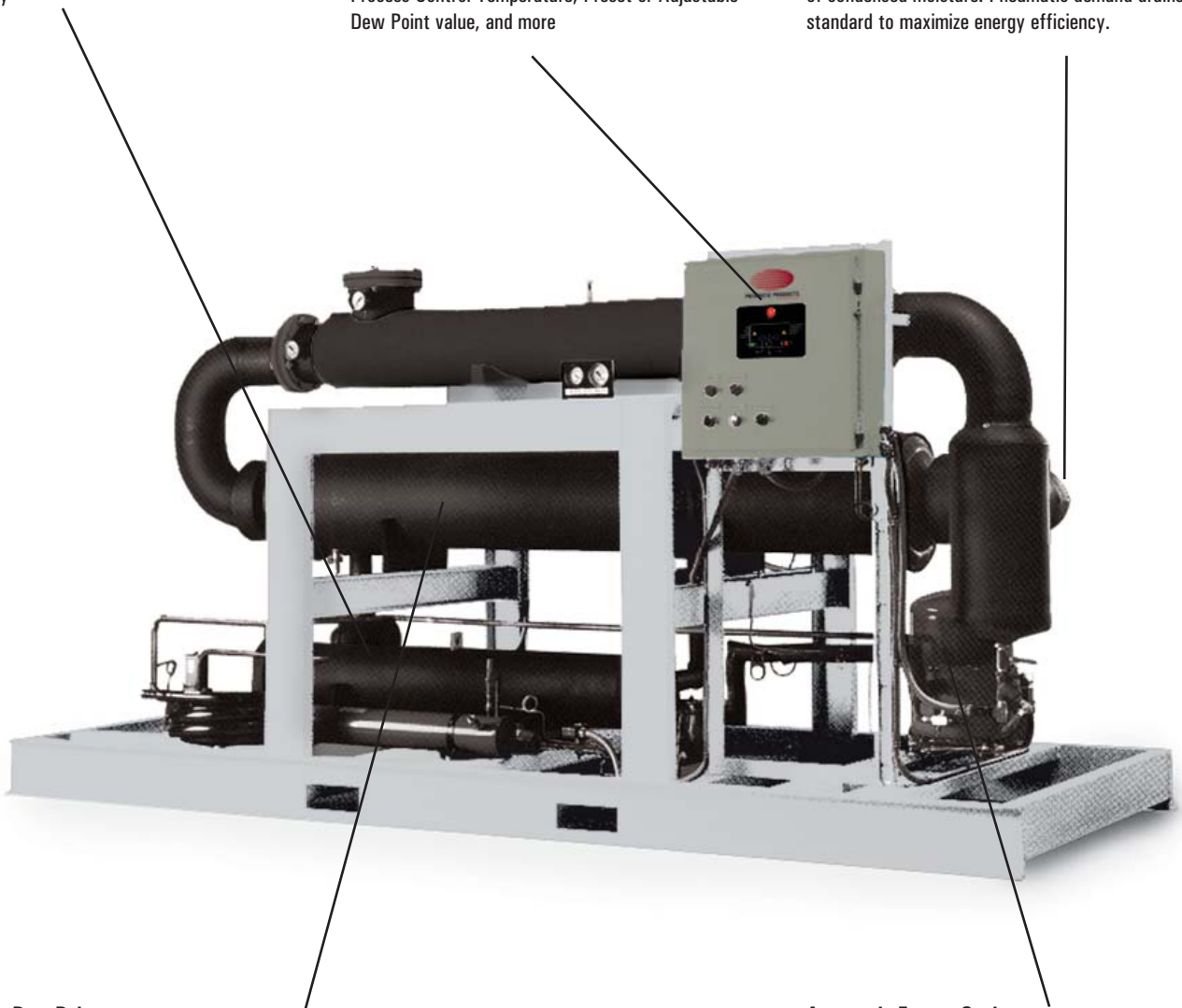

Consistent Dew Points

Non-fouling, smooth copper tubes, and shell type heat exchangers, deliver 33°F - 39°F dew points and low pressure drop.

Automatic Energy Savings

Compressor uses no energy once optimal thermal fluid storage system temperature is achieved

PNC & ESR Series Product Specifications

PNC Series Product Specifications

Model Number (3)	Capacity (1)		Compressor (hp) 38°F pressure dew point	Average Power (2)	Required Cooling Water Flow @ 85°F (gpm)	Water Conn In/Out FLG/NPT	Dimensions (4)						Inlet/Outlet 150# Flange	Approx Shipping Weight (5)				
	scfm	Nm3/min					kW	inches	H		W			L		inches	lbs	kg
									in	cm	in	cm		in	cm			
PNC4000	4,000	113.3	20	13.9	41.9	1½	85	208	94	231	63	155	8	5,200	2,359			
PNC5000	5,000	141.6	22	16.4	53.5	1½	90	221	107	263	63	155	8	6,000	2,722			
PNC6250	6,250	146.7	30	22.5	66.9	2	98	239	142	347	63	155	8	7,000	3,175			
PNC8250	8,250	233.6	35	28.9	85.6	2½	102	250	143	350	73	178	10	8,100	3,674			
PNC10000	10,000	283.2	50	39.6	121.6	2½	110	270	149	365	76	187	10	9,300	4,218			
PNC12000	12,000	339.8	60	49.6	146.8	2½	110	270	166	408	76	187	12	9,500	4,309			
PNC15000	15,000	424.8	70	57.6	205.3	Consult Factory												
PNC20000	20,000	566.3	80	54.6	204.5	Consult Factory												

Maximum Operating Pressure 150 psig (10.3 bar). Maximum Inlet Temperature: 120°F (49°C). Higher pressure and temperature rated models available - consult factory.

¹ Rated Flow Capacity - Conditions for rating dryers are in accordance with CAGI (Compressed Air and Gas Institute) Standard ADF100 working conditions: inlet air at 100 psig (7 bar) and 100°F (38°C) saturated, ambient air at 100°F (38°C), cooling water at 85°F (29°C), operating on 60Hz power supply. At rated conditions, outlet pressure dew points is 38°F (3°C).

² At 35°F (2°C) evaporator and 100°F (38°C) ambient

³ R404a refrigerant standard

⁴ Dimensions and weights are for reference only. Request certified drawings for construction purposes.

⁵ Weight shown is approximate for 38°F dew point water-cooled models only

ESR Series Product Specifications

Model Number (3)	Capacity (1)		Compressor (hp) 38°F pressure dew point	Average Power (2)	Required Cooling Water Flow @ 85°F (gpm)	Water Conn In/Out FLG/NPT	Dimensions (4)						Inlet/Outlet 150# Flange	Approx Shipping Weight (5)					
	scfm	Nm3/min					hp	kW	inches	H		W		L		inches	lbs	kg	
										in	cm	in		cm	in				cm
ESR4000	4,000	113	20	11.8	36.0	1½	79	201	60	152	125	318	8	10,100	4,591				
ESR5000	5,000	142	22	14.2	44.2	1½	79	201	60	152	154	391	8	12,400	5,637				
ESR6250	6,250	180	30	19.2	53.6	2	90	229	66	168	160	406	8	15,150	6,886				
ESR8250	8,250	234	35	24.4	71.4	2½	95	241	68	173	160	406	8	16,000	7,273				
ESR10000	10,000	283	50	33.5	98.6	2½	106	269	77	196	172	437	10	23,000	10,455				
ESR12000	12,000	340	60	41.5	118.5	2½	111	282	81	206	196	498	12	28,800	13,091				
ESR15000	15,000	424.8	70	48.5	Consult Factory														
ESR20000	20,000	566.3	80	46.1	Consult Factory														

Maximum Operating Pressure 150 psig (10.3 bar). Maximum Inlet Temperature: 120°F (49°C). Higher pressure and temperature rated models available - consult factory.

¹ Rated Flow Capacity - Conditions for rating dryers are in accordance with CAGI (Compressed Air and Gas Institute) Standard ADF100 working conditions: inlet air at 100 psig (7 bar) and 100°F (38°C) saturated, ambient air at 100°F (38°C), cooling water at 85°F (29°C), operating on 60Hz power supply. At rated conditions, outlet pressure dew points is 38°F (3°C).

² At 35°F (2°C) evaporator and 100°F (38°C) ambient

³ R22 refrigerant standard

⁴ Dimensions and weights are for reference only. Request certified drawings for construction purposes.

⁵ Weight shown is approximate for 38°F dew point water-cooled models only

Table 1 - Correction Factors (multipliers) for Inlet Air Temperature and Pressure

Inlet Pressure (psig)	Inlet Temperature				
	80°F (27°C)	90°F (32°C)	100°F (38°C)	110°F (43°C)	120°F (49°C)
50	1.35	1.05	0.84	0.69	0.56
80	1.50	1.17	0.95	0.79	0.66
100	1.55	1.23	1.00	0.82	0.70
125	1.63	1.31	1.07	0.91	0.74
150	1.70	1.37	1.13	0.95	0.80

Table 2 - Correction Factors for Dew Point Temperatures

Dew Point Temperature	38°F (30°C)	45°F (70°C)	50°F (100°C)
Multiplier	1.0	1.2	1.3

To adjust dryer capacity for conditions other than rated. Use Correction Factors (multipliers) from Tables 1 and 2.

Example: What is the capacity of a 6,250 scfm model when the compressed air at the inlet to the dryer is at 150 psig and 100°F (38°C)? The max cooling water temperature is 85°F (29.4°C) and a 50°F (10°C) dew point is desired.

Answer: 6,250 scfm (rated flow from Specifications Table) x 1.13 (correction factor for inlet temperature and pressure from Table 1) x 1.3 (correction factor for dew point from Table 2) = 9,181 scfm.

SPX PNEUMATIC PRODUCTS

SPX Air Treatment

4647 S.W. 40th Avenue

Ocala, Florida 34474-5788 U.S.A.

Phone: 352-873-5793 • Fax: 352-873-5770

Email: pneumatic.products.sales@airtreatment.spx.com

www.pneumaticproducts-spx.com

Improvements and research are continuous at SPX Pneumatic Products. Specifications may change without notice.

Bulletin OFR-8100-NA-1