

High performance liquid-solids separation systems

JPX

Exclusive internal acceleration creates maximum performance to achieve maximum protection of fluid handling systems from unwanted solids (see illustration inside for details). Its advanced & patented design, building upon the performance LAKOS is known for, now also removes 50% more of the finer solids (< 40 microns), resulting in higher aggregate solids removal. Independently tested. Proven superior for today's demanding filtration requirements. For settleable solids only.

Trouble-free operation & advanced purging/solids-handling concepts keep fluids clean and concentrate separated solids

No screens or filter elements to clean or replace; no messy servicing routines

No backwashing; zero fluid loss options

Low & steady pressure loss

Choice of profiles to accommodate space/piping limitations

Rigid couplings for fast and easy internal access

Swirlex internal accelerating slots for optimum solids-removal performance; patented; optional annular transfer ring for handling larger solids/fibrous materials

Vortube for enhanced solids separation/collection; patented

Grooved inlet/outlet connections for easy installation; optional flanged connections also available

In-line inlet/outlet configuration for simplified piping (low-profile models only)

Unishell construction for easy installation

Optional material construction & ASME code

Flow range:
4 - 12,750 U.S. gpm
(1 - 2895 m³/hr) per unit

Maximum standard pressure rating:
150 psi (10.3 bar)



JPX Series includes inlet/outlet pressure gauges with petcock valves and a manual isolation valve for the purge outlet.

Also available with weld-on flanges. See page 3 for other details.



How-it-Works Illustration

Model Specifications

Installation & Operating Instructions

Maintenance & Purging

Engineering Specifications

How It Works

Automatic Purging

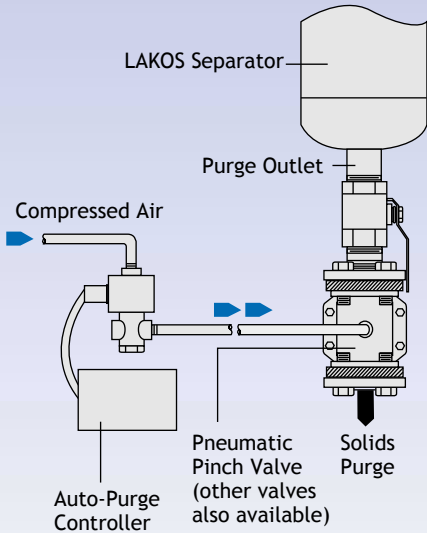

Solids Handling Options

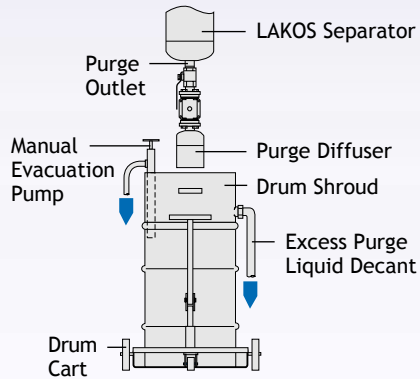

Systems also available with a tilt-style hopper.

LAKOS products are manufactured and sold under one or more of the following U.S. Patents: 3,289,608; 3,512,651; 3,568,837; 3,701,425; 3,947,364; 3,963,073; 4,027,481; 4,120,795; 4,123,800; 4,140,638; 4,147,630; 4,148,735; 4,305,825; 4,555,333; 5,320,747; 5,338,341; 5,368,735; 5,425,876; 5,571,416; 5,578,203; 5,622,545; 5,653,874; 5,894,995; Des. 327,693 and corresponding foreign patents. Other U.S. and foreign patents pending.

Pressure gauges with petcock valves (included as standard) to monitor proper flow range (see "Flow vs. Pressure Loss", page 3)

Fluid and pressure drawn by Vortube to more positively allow even finer solids to be drawn into solids collection chamber (Separated, instead of entering vortex flow to outlet)

Manual Isolation Valve (included as standard) provides for removal of Auto Purge valve for servicing

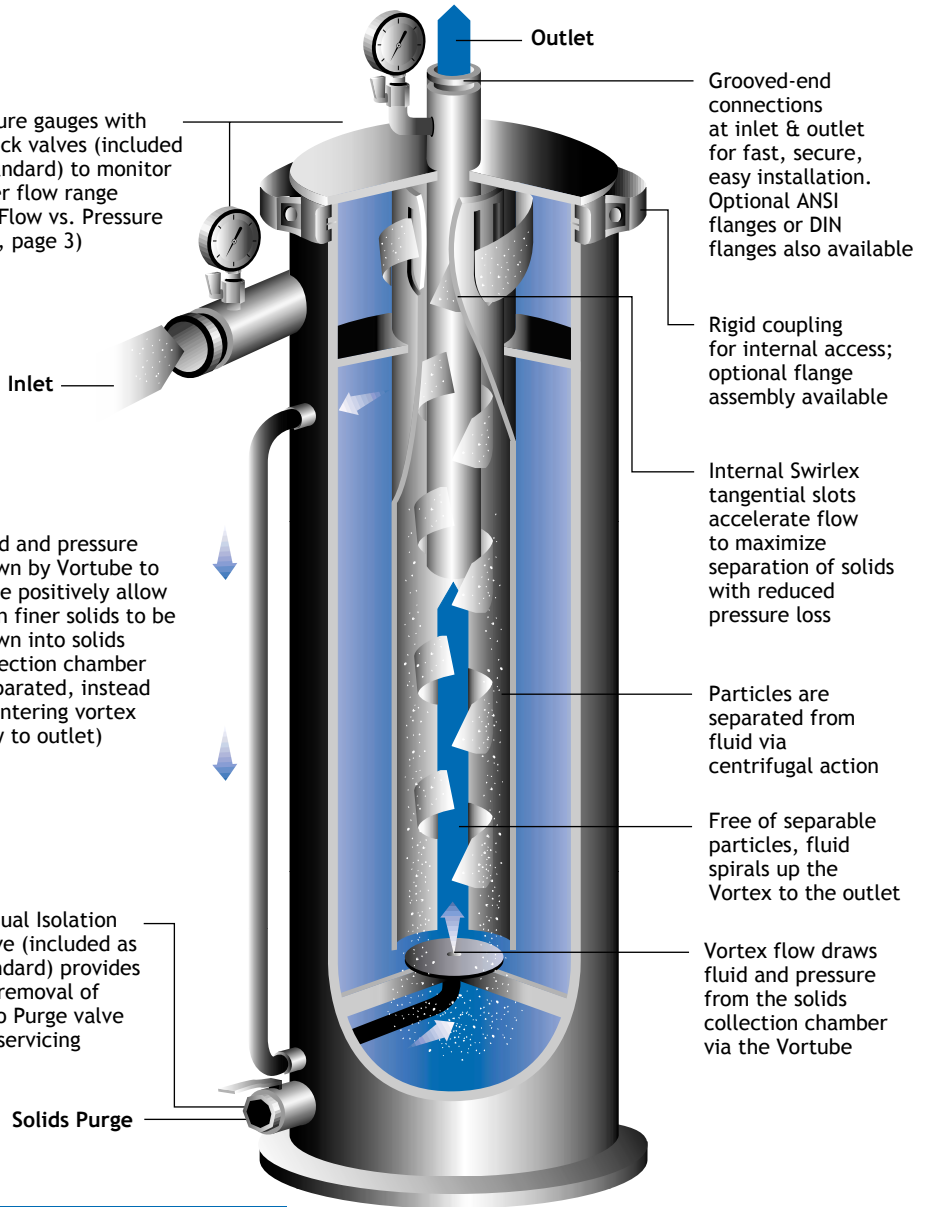

Performance

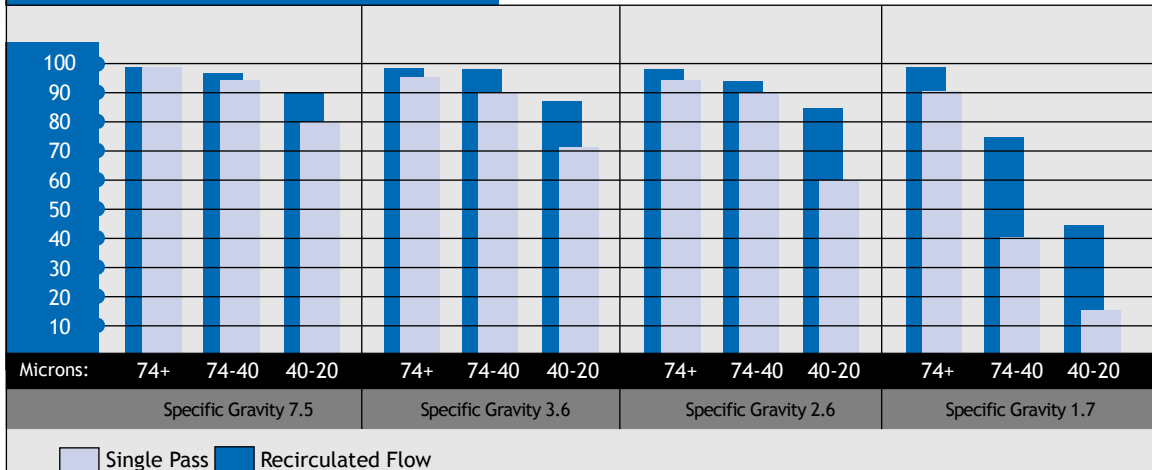

Specifications

Model*	Flow Range		Inlet/Outlet Grooved Coupling**	Purge Size Male N.P.T.	Collection Chamber Capacity		Weight		Weight with Water	
	U.S. gpm	m ³ /hr			gal	liters	lbs.	kg	lbs	kg
JPX-0004	4-10	1-2.5	1/2" NPT**	2"	0.09	0.3	22	10	25	11
JPX-0010	10-20	2.5-4.5	3/4" NPT**	2"	0.11	0.4	31	14	37	17
JPX-0016	16-30	4 -7	1"	2"	0.15	0.6	40	18	51	23
JPX-0028	28-45	7-10	1-1/4"	2"	0.27	1.0	59	27	77	35
JPX-0038	38-65	9-15	1-1/2"	2"	0.4	1.5	85	39	115	52
JPX-0060	60-100	14-23	2"	2"	0.8	3.0	150	68	221	101
JPX-0085	85-145	19-33	2-1/2"	2"	0.8	3.0	194	88	278	126
JPX-0130	130-225	30-51	3"	2"	0.8	3.0	202	92	290	132
JPX-0200	200-325	45-74	4"	2"	1.6	6.1	327	149	507	231
JPX-0285-L JPX-0285-V	285-525	65-120	4"	2"	2.1 5.4	7.9 20.5	510 474	232 216	820 758	373 345
JPX-0450-L JPX-0450-V	450-825	102-187	6"	2"	2.8 6.7	10.6 25.4	738 697	336 317	1202 1132	546 515
JPX-0650-L JPX-0650-V	650-1200	150-275	6"	2"	4.3 10.4	16.3 39.4	929 898	422 408	1627 1554	740 706
JPX-1160-L JPX-1160-V	1160-2150	265-490	8"	2"	8.6 20.5	32.6 77.6	1391 1411	632 641	2716 2665	1235 1211
JPX-1850-L JPX-1850-V	1850-3400	420-775	10"	2"	15.0 31.5	56.8 119.2	1853 1937	842 880	3991 3951	1814 1796
JPX-2650-L JPX-2650-V	2650-4900	600-1115	12"	2"	23.5 51.1	89.0 193.4	3077 3254	1399 1479	6269 6287	2850 2858
JPX-4200-L JPX-4200-V	4200-7800	950-1775	16"	3"	52.2 99.3	197.6 375.9	5074 5574	2306 2534	11791 11944	5360 5430
JPX-6700-L JPX-6700-V	6700-12750	1520-2895	20"	3"	81.0 162.3	306.6 614.4	7808 8527	3549 3876	18660 18855	8482 8571

* Models ending with "L" are low profile; "V" for vertical profile

** Inlet/Outlet may also be specified with ANSI flanges or DIN flanges; JPX-0004 and JPX-0010 are standard male, N.P.T. (BSP or JIS threads available); other models also available with optional threading

Maximum pressure rating: 150 psi (10.3 bar); consult factory for higher pressure requirements

Pressure loss range: 3 - 12 psi (.2 - .8 bar)

Maximum particle size: JPX-0016 and smaller - .25 inch (6 mm); all other models - .375 inch (9 mm)

Material (standard carbon steel): Domes - A 285C/516 GR70, .25 inch (6 mm) minimum thickness

Other parts - A-36, A-53B or other quality grade, .25 inch (6 mm) minimum thickness; special coatings and other materials available - consult factory

Paint coating: Acrylic urethane, spray-on royal blue

Flow vs. Pressure Loss

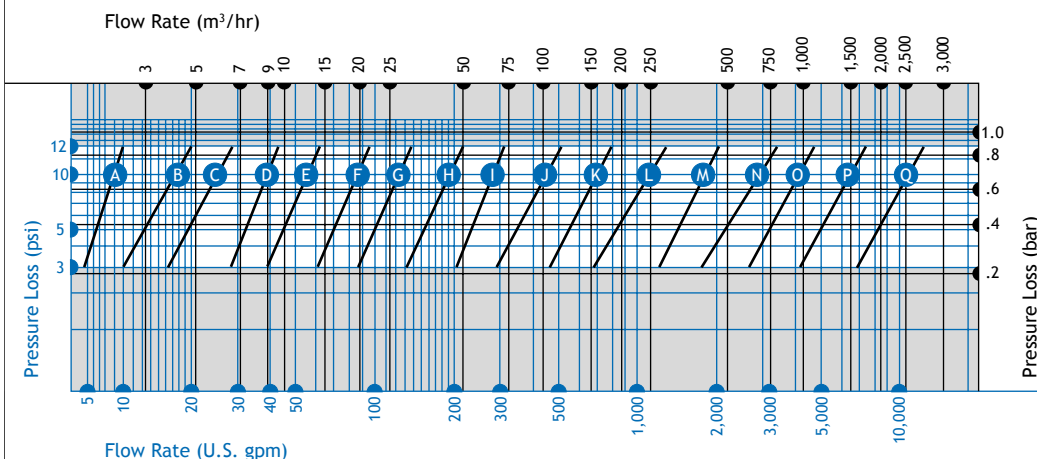

- A JPX-0004
- B JPX-0010
- C JPX-0016
- D JPX-0028
- E JPX-0038
- F JPX-0060
- G JPX-0085
- H JPX-0130
- I JPX-0200
- J JPX-0285
- K JPX-0450
- L JPX-0650
- M JPX-1160
- N JPX-1850
- O JPX-2650
- P JPX-4200
- Q JPX-6700

Installation Instructions

Maintenance/Purging

1. LAKOS JPX Separators must be purged regularly to remove the separated solids from the temporary collection chamber.
2. All purge hardware should be installed prior to any elbows or turns in the purge piping. Avoid "uphill" purging, which can clog purge piping and hinder effective solids evacuation.
3. For best results, purging is recommended while the LAKOS Separator is in operation, utilizing system pressure to enhance solids evacuation.
4. LAKOS provides a full selection of rugged, durable automatic purging and solids-handling systems to optimize the performance of your separation system.
CAUTION: Economy-type valves typically fail prematurely in the harsh/abrasive environment of solids purging.
5. Be sure to install the manual isolation valve (provided as standard) prior to the automatic valve (available from LAKOS at additional cost) in order to facilitate servicing of the automatic valve without system shutdown.
6. Internal Access Feature:
To inspect or clear an unusual blockage in the upper or lower chamber, interrupt flow to the LAKOS Separator and relieve pressure (via the purge valve). For upper chamber access, remove the spool from the separator's outlet (or, if no spool has been installed, disconnect and remove piping on the outlet) to make space for removing the separator's upper section. Disconnect the rigid coupling and carefully pull out the separator's vortex outlet assembly. Inspect or clean the inlet chamber as necessary. Lubricate the coupling's seal before re-installing the vortex assembly. Re-install piping and gaskets as necessary.

1. LAKOS JPX Separators are shipped on skids or in wooden crates. Support legs (when applicable) are detached for shipping. A large ring, located on the unit's side or upper chamber, is provided for hoisting as necessary.
2. A suitable foundation is necessary to accommodate the LAKOS Separator's weight including liquid (see data, page 3). Anchor bolts are recommended in the base of the legs (low profile) or skirt (vertical profile).
3. Prior to installation, inspect the inlet/outlet/purge connections for foreign objects incurred during shipping/storage.
4. Inlet/outlet pipe connections to the LAKOS Separator should be a straight run of at least five pipe diameters to minimize turbulence and enhance performance.
5. Proper purge hardware and/or solids-handling equipment is required to flush separated solids from the separator (see details, page 2).
6. All LAKOS Separators operate within a prescribed flow range (see data, page 3). Pipe size is not a factor in model selection. Use appropriate hardware to match the inlet/outlet size. Grooved couplings are not included with the separator. Optional flanged connections are available upon request.
7. Inlet pressure to the LAKOS Separator must be at least equal to or greater than the anticipated pressure loss through the separator (see pressure loss chart, page 3) plus 15 psi (1 bar) plus whatever downstream pressure is required.
8. Pressure gauges (provided as standard, with petcock valves) are required at both the inlet and outlet of the separator in order to monitor pressure loss and proper system flow (see "Flow vs. Pressure Loss" chart, page 3). If separator operates with an open discharge, a valve should be installed to create a back pressure of at least 5 psi (.3 bar).
9. Winterizing is important if the LAKOS Separator is to remain idle in freezing temperatures. Drain liquid as necessary to avoid expansion of water to ice and related damages.

Low Flow Rates

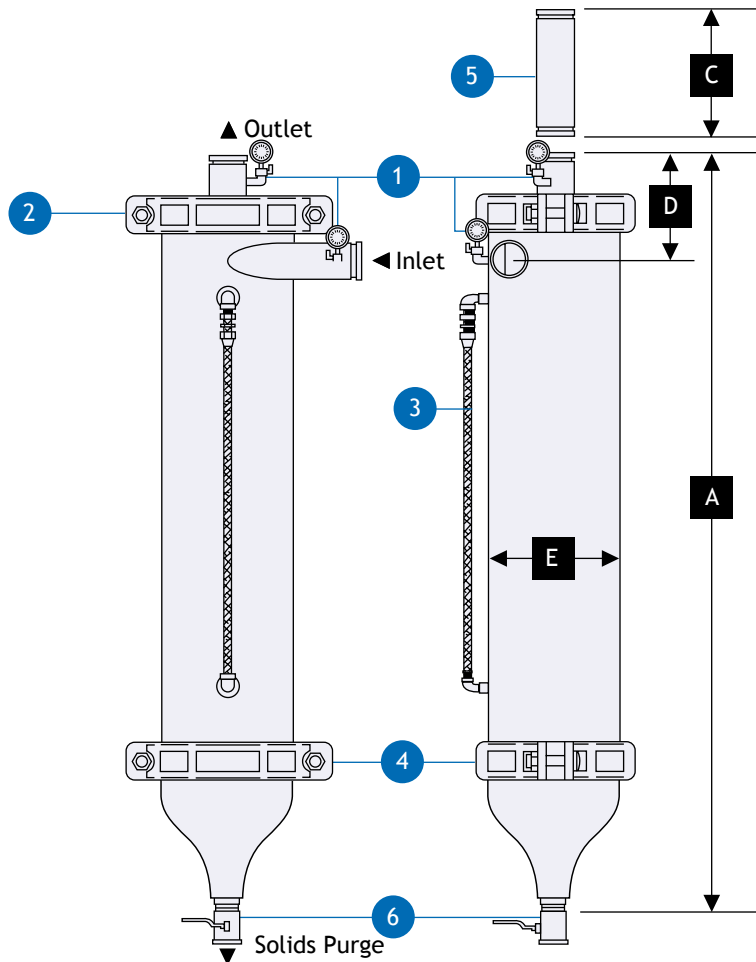

Top View

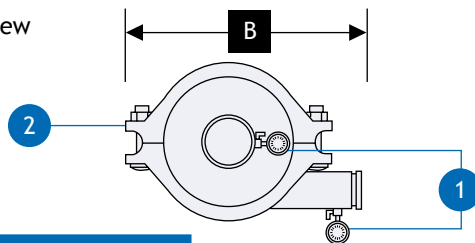

Dimensions

Model	A		B		C		D		E	
	in	mm	in	mm	in	mm	in	mm	in	mm
JPX-0004	28-1/8	714	7 1/4	184	6	152	5-1/4	133	3-1/2	89
JPX-0010	31-3/8	797	7 1/2	191	7	178	6-3/8	162	4	102
JPX-0016	33-7/8	860	8 3/4	222	7	178	7	178	4-1/2	114
JPX-0028	38	965	10 7/8	276	7	178	7	178	5-9/16	141
JPX-0038	42-1/4	1073	12 3/8	314	8	203	7	178	6-5/8	168
JPX-0060	51-7/8	1318	15 3/4	400	11	279	7-1/4	184	8-5/8	219
JPX-0085	59-1/4	1505	15 3/4	400	15	381	8	203	8-5/8	219
JPX-0130	61-1/4	1556	15 3/4	400	16	406	8	203	8-5/8	219
JPX-0200	75-5/8	1921	19 3/8	492	21	533	8-3/4	222	10-3/4	273

1 Inlet/Outlet Pressure Gauges with Petcock Valves

Included as standard; Install at both inlet and outlet for proper flow verification (see "Flow vs. Pressure Loss", page 3)

2 Rigid Coupling Connection

Provides for complete access to the upper chamber, acceleration slots and internal separation barrel; 2-piece; standard EPDM gasket - also available in Nitrile, Silicone, Fluoroelastomer or White Nitrile

3 Vortube

Piping provided by LAKOS

4 Rigid Coupling Access

Provides full access to collection chamber area for inspection/servicing; standard EPDM gasket - also available in Nitrile, Silicone, Fluoroelastomer or White Nitrile

5 Connection Spool

When removed, provides space for accessing internals of separator via rigid coupling. Not included with separator, available separately

6 Manual Isolation Valve

Included as standard to provide for removal of Auto Purge valve for servicing; Also included with separator are the following threaded reducers: 2" x 1-1/2", 2" x 1" and 2" x 3/4" for your choice of purge equipment

Note: These units may also be specified with optional support skirt or legs. Consult factory for details.

Low Profile

High Flow Rates

1 Inlet/Outlet Pressure Gauges with Petcock Valves

Included as standard; Install at both inlet and outlet for proper flow verification (see "Flow vs. Pressure Loss", page 3)

2 Inspection/Drain Plug

1/2-inch NPT female; provides access to upper chamber for inspection of slot area; also allows for draining the upper chamber if necessary

3 Rigid Coupling Connection

Provides for complete access to the upper chamber, acceleration slots and internal separation barrel; standard EPDM gasket - also available in Nitrile, Silicone, Fluoroelastomer, Black Neoprene or White Nitrile

4 Lifting Ring

For installation purposes

5 Connection Spool

When removed, provides space for accessing internal of separator via rigid coupling. Not included with separator, available separately

6 Hand-Hole Inspection Port

Provides access to collection chamber; Neoprene gasket

7 Vortube

Piping provided by LAKOS

8 Manual Isolation Valve

Included as standard to provide for removal of Auto Purge valve for servicing

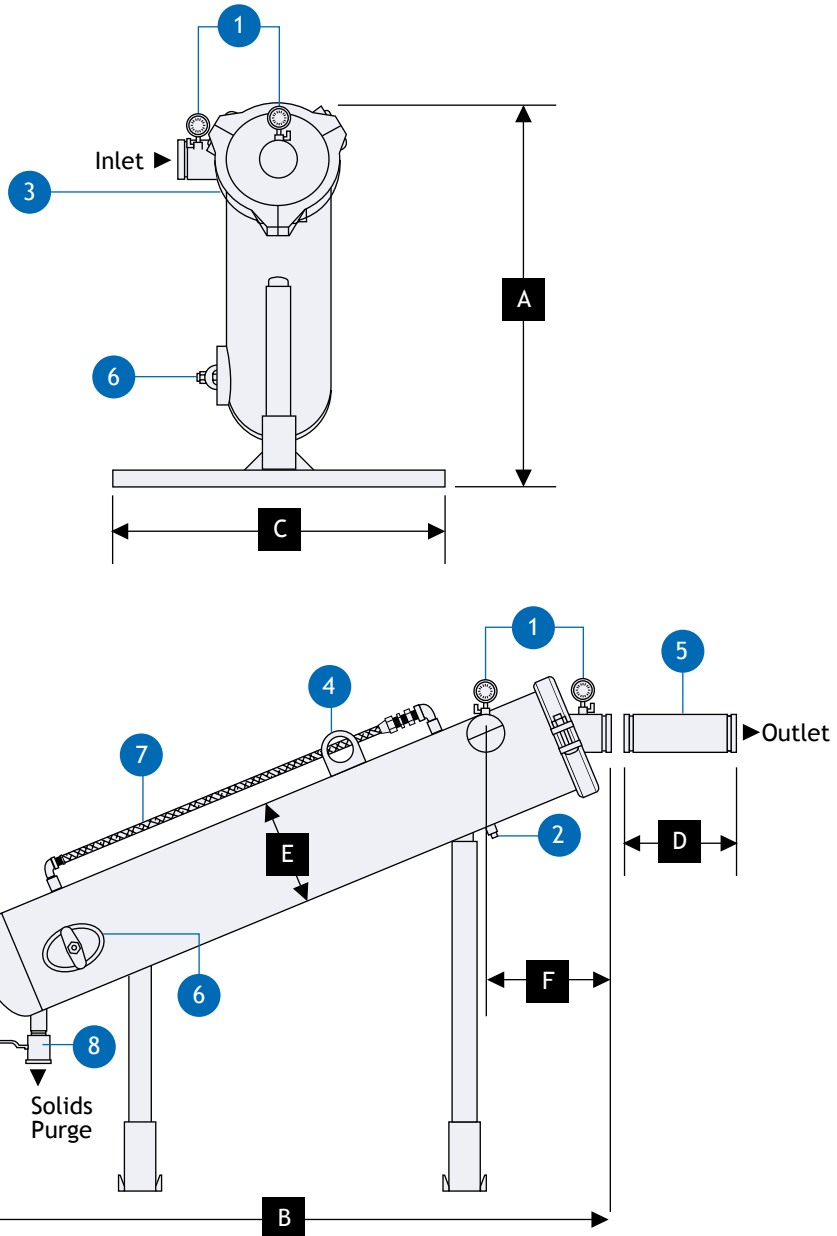

Dimensions

Model	A		B		C		D		E		F	
	in	mm	in	mm	in	mm	in	mm	in	mm	in	mm
JPX-0285-L	77-1/4	1962	78	1981	40	1016	16	406	12-3/4	324	15	381
JPX-0450-L	84-1/4	2140	94-1/2	2400	40	1016	20	508	14	356	16	406
JPX-0650-L	90-3/4	2305	105-3/4	2686	40	1016	24	610	16	406	18	457
JPX-1160-L	104-1/4	2648	126-3/4	3219	40	1016	30	762	20	508	22	559
JPX-1850-L	113-1/2	2883	141-5/8	3597	40	1016	33	838	24	610	26	660
JPX-2650-L	123-1/2	3137	158	4013	60	1524	38	965	28	711	30	762
JPX-4200-L	147	3734	198	5029	60	1524	51	1295	36	914	38-1/2	978
JPX-6700-L	166-1/4	4223	234	5944	60	1524	60	1524	42	1067	44	1118

High Flow Rates

Vertical Profile

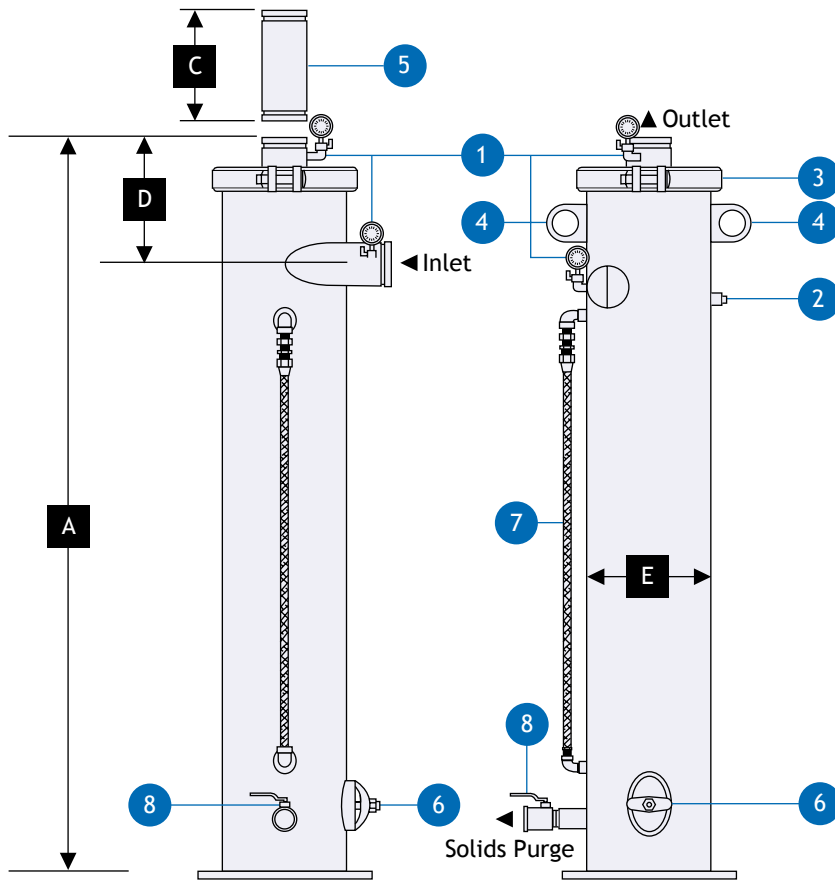

1 Inlet/Outlet Pressure Gauges with Petcock Valves

Included as standard; Install at both inlet and outlet for proper flow verification (see "Flow vs. Pressure Loss", page 3)

2 Inspection/Drain Plug

1/2-inch NPT female; provides access to upper chamber for inspection of slot area; also allows for draining the upper chamber if necessary

3 Rigid Coupling Connection

Provides for complete access to the upper chamber, acceleration slots and internal separation barrel; standard EPDM gasket - also available in Nitrile, Silicone, Fluoroelastomer, Black Neoprene or White Nitrile

4 Lifting Rings

For installation purposes

5 Connection Spool

When removed, provides space for accessing internal of separator via rigid coupling. Not included with separator, available separately

6 Hand-Hole Inspection Port

Provides access to collection chamber; Neoprene gasket

7 Vortube

Piping provided by LAKOS

8 Manual Isolation Valve

Included as standard to provide for removal of Auto Purge valve

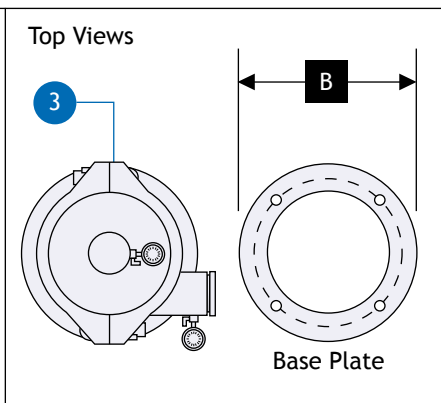
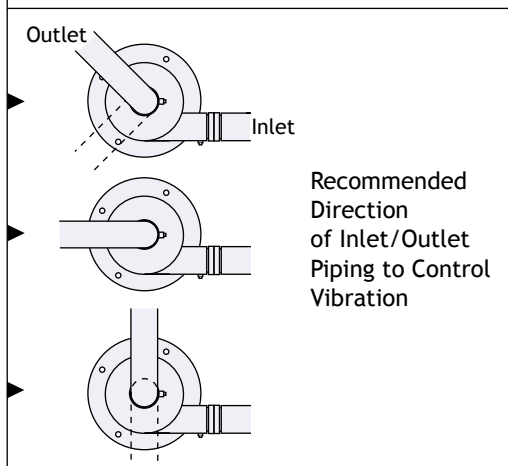

Dimensions

Model	A		B		C		D		E	
	in	mm	in	mm	in	mm	in	mm	in	mm
JPX-0285-V	76	1930	18	457	16	406	13	330	12-3/4	324
JPX-0450-V	93-1/2	2375	20	508	20	508	12-1/2	318	14	356
JPX-0650-V	105-3/4	2686	22	559	24	610	14-7/8	378	16	406
JPX-1160-V	126-3/8	3210	26	660	30	762	17-3/4	451	20	508
JPX-1850-V	139-1/2	3543	32	813	33	838	20	508	24	610
JPX-2650-V	155-1/2	3950	36	914	38	965	23	584	28	711
JPX-4200-V	194-1/2	4940	44	1118	51	1295	29	734	36	914
JPX-6700-V	229	5817	48	1219	60	1524	32-3/4	832	42	1067

Sample Specifications

Limited Warranty

All products manufactured and marketed by this corporation are warranted to be free of defects in material or workmanship for a period of at least one year from date of delivery. Extended warranty coverage applies as follows:

All LAKOS Separators: Five year warranty

All other components: 12 months from date of installation; if installed 6 months or more after ship date, warranty shall be a maximum of 18 months from ship date.

If a fault develops, notify us, giving a complete description of the alleged malfunction. Include the model number(s), date of delivery and operating conditions of subject product(s). We will subsequently review this information and, at our option, supply you with either servicing data or shipping instruction and returned materials authorization. Upon prepaid receipt of subject product(s) at the instructed destination, we will then either repair or replace such product(s), at our option, and if determined to be a warranted defect, we will perform such necessary product repairs or replace such product(s) at our expense.

This limited warranty does not cover any products, damages or injuries resulting from misuse, neglect, normal expected wear, chemically-caused corrosion, improper installation or operation contrary to factory recommendation. Nor does it cover equipment that has been modified, tampered with or altered without authorization.

No other extended liabilities are stated or implied and this warranty in no event covers incidental or consequential damages, injuries or costs resulting from any such defective product(s).

Separator Type & Performance

The removal of specific unwanted solids from a pumped/pressurized fluid flow system shall be accomplished with a centrifugal-action vortex separator. Solids removal efficiency is principally predicated on the difference in specific gravity between the liquid and the solids. Fluid viscosity must be 100 SSU or less.

In a single pass through the separator, given solids with a specific gravity of 2.6 and water at 1.0, performance is predictably 98% of 74 microns and larger. Additionally, particles finer in size, heavier by specific gravity and some lighter by specific gravity will also be removed, resulting in an appreciable aggregate removal of particles (up to 75%) as fine as 5 microns.

In a recirculating system, 98% performance is predictable to as fine as 40 microns (given solids with a specific gravity of 2.6), with correspondingly higher aggregate performance percentages (up to 90%) of solids as fine as 5 microns.

Separator Design & Function

A tangential inlet and mutually tangential internal accelerating slots shall be employed to promote the proper velocity necessary for the removal of the separable solids. The internal accelerating slots shall be spiral-cut (Swirlx) for optimum flow transfer, laminar action and particle influence into the separation barrel. The separator's internal vortex shall allow this process to occur without wear to the accelerating slots.

Separated particle matter shall spiral downward along the perimeter of the inner separation barrel, in a manner that does not promote wear of the separation barrel, and into the solids collection chamber, located below the vortex deflector stool.

To insure maximum particle removal characteristics, the separator shall incorporate a vortex-induced pressure relief line (Vortube), drawing specific pressure and fluid from the separator's solids collection chamber via the outlet flow's vortex/venturi effect, thereby efficiently encouraging solids into the collection chamber without requiring a continuous underflow or excessive system fluid loss.

System fluid shall exit the separator by following the center vortex in the separation barrel and spiral upward to the separator outlet.

Purging (as a specified option)

Evacuation of separated solids shall be accomplished automatically, employing a dedicated solid-state controller in a NEMA 4 housing. Available for worldwide single-phase voltages of 24VAC to 250VAC. Programming options to include a purge frequency range of every 60 seconds to every 23 hours, 59 minutes. Purge duration options range from 2 seconds to 59 minutes, 59 seconds. Non-volatile memory. Meets CSA requirements. This controller shall automatically operate one of the following techniques:

Motorized Ball Valve - A full-port, electrically-actuated valve shall be programmed at appropriate intervals and duration in order to efficiently and regularly purge solids from the separator's collection chamber. Valve body shall be bronze (optional stainless steel also available). Valve ball shall be stainless steel with teflon seat. Valve size: _____

Pneumatic Pinch Valve - Compressed air shall be provided to actuate this full-port valve at appropriate intervals and duration in order to efficiently and regularly purge solids from the separator's collection chamber. System shall include a pressure regulator for proper modulation of air pressure. Valve liner is natural gum rubber (other liner materials available). Valve size: _____

Pneumatic Ball Valve - A fail-safe valve shall be programmed at appropriate intervals and duration in order to efficiently and regularly purge solids from the separator's collection chamber. A spring-control shall provide that this full-port valve closes in the event that compressed air or electricity is interrupted. Valve body shall be bronze (optional stainless steel also available). Valve ball shall be stainless steel with teflon seat. Valve size: _____

Purge Liquid Concentrator - A dual pneumatic pinch valve package shall be employed in order to effectively minimize the fluid loss when purging. The controller shall provide proper sequential valve actuation at appropriate intervals and duration in order to efficiently and regularly evacuate solids from the separator's collection chamber. Liners for the pinch valves shall be natural gum rubber (optional, at extra cost: neoprene, butyl, buna N and hypalon also may be specified). System shall also include a pressure regulator to modulate air pressure to the valves, a full-size sightglass for inspection of solids accumulation during operation and a manual isolation valve for servicing requirements. Valve size: _____

Solids Handling (as a specified option)

An appropriate solids collection device shall be provided with the separator, suitable for capturing solids and returning all excess purged liquid to system use. Size and type of collection device shall be determined according to the application requirements, selected from the following options (or custom, as specified):

Solids Collection Drum - In conjunction with the appropriate automatic purge valve, this package shall be employed to capture and concentrate separated solids (up to 90% solids by volume) from the separator directly into a standard 55-gallon drum, returning excess purged liquid to system use via an integral decant line on the drum shroud. Solids collection capacity: 12,700 cubic inches (200 liters). Package includes two shrouds, two shroud clamps, two drum carts for transporting the drums and a manual liquid evacuation pump. Recommended option: A Purge Diffuser shall be installed on the discharge of the automatic purge valve in order to reduce the velocity of the purge flow and enhance the settling of solids within the drum.

Solids Collection Hopper - In conjunction with the appropriate automatic purge valve, a one cubic yard (764 liter) hopper shall be employed to capture and concentrate separated solids (up to 90% by volume) from the separator, returning excess purged liquid to system use via an integral decant line installed directly on the hopper. The hopper shall feature a manually-actuated tilting mechanism for dumping accumulated solids as necessary. Recommended option: A Purge Diffuser shall be installed on the discharge of the automatic purge valve in order to reduce the velocity of the purge flow and enhance the settling of solids within the hopper.

Systemization (as a specified option)

The separator and its accessories shall be packaged as a complete system, with all componentry from a single source. In addition to the equipment already specified, the system shall also include an appropriate support frame for positioning the separator accurately and effectively for solids purging/handling. If the specified purging technique is a pneumatic pinch valve: A spare pinch valve liner shall also be included.

Separator Details

- Inlet & outlet shall be grooved couplings, size: _____
- Purge outlet shall be threaded with screw-on flange, size: _____
- Control shall operate within a flow range of: _____
- Pressure loss shall be between 3-12 psi (.2 - .8 bar), remaining constant, varying only when the flow rate changes.
- Included shall be pressure gauges with petcock valves for both the inlet and outlet of the separator and an isolation valve at the purge outlet for servicing of the automatic valve as necessary without interrupting system flow.

Separator Construction

The separator shall feature the following access capabilities for either inspection or the removal of unusual solids/debris:

- An upper-chamber full-size grooved coupling, allowing complete access to the inlet chamber, acceleration slots and internal separation barrel
- A hand-hole port at the collection chamber, with Neoprene gasket (low flow rate models to feature full-size coupling at collection chamber)
- An inspection port, located at the lowest point of the upper chamber

The separator shall be of unishell construction with A-36, A-53B or equivalent quality carbon steel, minimum thickness of .25 inches (6mm). Maximum operating pressure shall be 150 psi (10.3 bar), unless specified otherwise.

Paint coating shall be oil-based enamel, spray-on, royal blue.

As a specified option only: The separator shall be constructed in accordance with the standards of the American Society of Mechanical Engineers (ASME), Section VIII, Division 1 for pressure vessels. Certification shall be confirmed with the registered "U-stamp" on the body of the separator. Weld-on flanges also available.

Separator Source & Identification

The separator shall be manufactured by LAKOS Filtration Systems, a division of Claude Laval Corporation in Fresno, California USA. Specific model designation is: _____