

Electropneumatic Positioner Type 3730-5 with FOUNDATION™ Fieldbus communication

Application

Positioner for attachment to pneumatic control valves

Travel: 3.6 to 200 mm · Opening angle: 24° to 100°

Smart, bus-powered field unit conforming to FOUNDATION™ Fieldbus specification based on EN 61158-2 transmission technology. Integrated Function Blocks: PID Process Controller, AO Analog Output, 2 DI Discrete Inputs, and Link Master Capability.



The microprocessor-controlled positioner compares the reference variable cyclically transmitted over the FOUNDATION™ Fieldbus network to the travel or opening angle of the control valve and issues a corresponding output signal pressure.

The Type 3730-5 Positioner communicates according to FOUNDATION™ Fieldbus specification with field devices, programmable logic controllers and process control systems.

An integrated PID Function Block allows the control of process variables required directly in the field. The shift to distributed control reduces the number of control tasks to be performed by the higher-level automation system. Thanks to the Link Master Capability, autonomous closed control loops can be set up in the field.

Other benefits provided by the smart positioner:

- Easy attachment to common linear actuators over SAMSON direct attachment interface (Fig. 1), over NAMUR rib (Fig. 2) or to control valves with rod-type yokes according to IEC 60534-6 or to rotary actuators according to VDI/VDE 3845 (Fig. 3)
- Any desired mounting position
- Simple one-knob, menu-driven operation
- Variable, automatic start-up with four different initialization modes
- LCD easy to read in any mounting position due to selectable reading direction
- Integrated EXPERT diagnostics (see T 8388 EN)
- Classified status alarms
- Control parameters can be changed online
- Configurable at a computer over the SSP serial interface using TROVIS-VIEW software
- Automatic monitoring of zero point
- Two DI Blocks to analyze binary input signals
- Calibrated travel sensor without gears susceptible to wear
- Permanent storage of all parameters in non-volatile EEPROM (protection against power failure)
- Adjustable output pressure limitation
- Adjustable tight-closing function
- Binary input for DC voltage signals
- Certified according to IEC 61508/SIL

Additional options

- Inductive limit switch with proximity switch

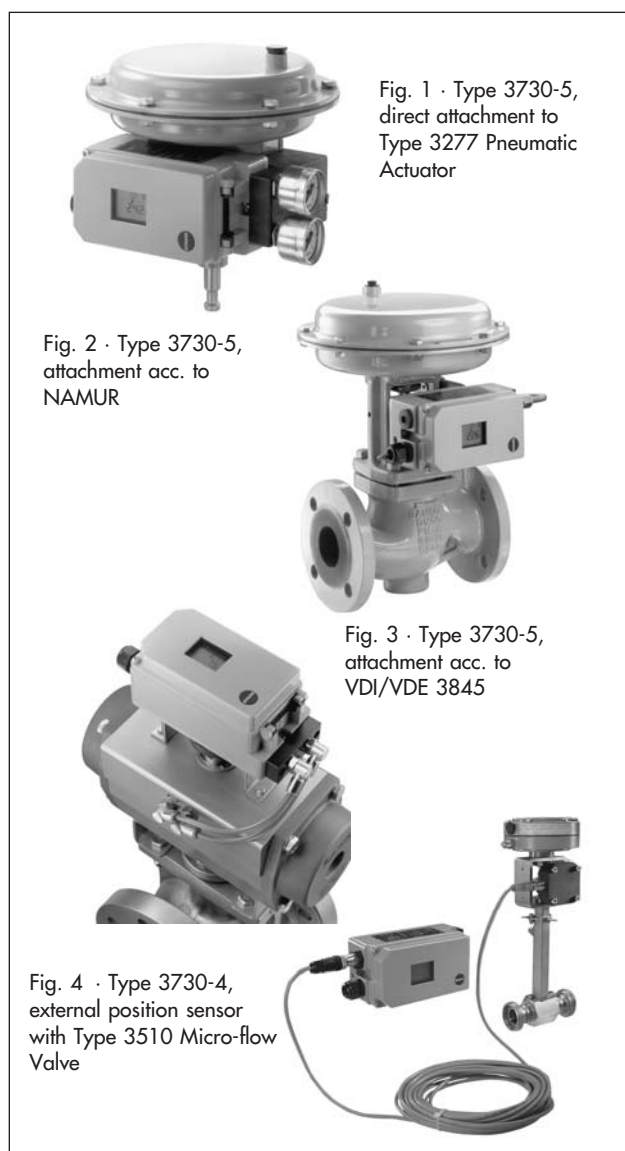

Fig. 1 · Type 3730-5, direct attachment to Type 3277 Pneumatic Actuator

Fig. 2 · Type 3730-5, attachment acc. to NAMUR

Fig. 3 · Type 3730-5, attachment acc. to VDI/VDE 3845

Fig. 4 · Type 3730-4, external position sensor with Type 3510 Micro-flow Valve

- Integrated solenoid valve
- Binary input for floating contact
- External position sensor (Fig. 4)
- Integrated EXPERT+ extended diagnostics (T 8388 EN)
- Stainless steel housing

Table 1 · Technical data for Type 3730-5 FOUNDATION™ Fieldbus Positioner

Rated travel	adjustable	Direct attachment to Type 3277 Actuator	3.6 to 30 mm
		Attachment according to IEC 60534-6 (NAMUR)	3.6 to 200 mm
		Attachment to rotary actuators (VDI/VDE 3845)	24 to 100° opening angle
Travel range	adjustable	Within the initialized travel/angle of rotation; restricted to 1/5 at the maximum	
Bus connection		Fieldbus interface as per	EN 61158-2, bus-powered
		Physical Layer Class	113 (without explosion protection) 111 (explosion-protected version)
		Field device acc. to	FM 3610 entity, FISCO and FNICO
Communication			
Fieldbus		Data transmission conforming to FOUNDATION™ Fieldbus specification, Communication Profile Class: 31 PS, 32 L; Interoperability tested acc. to Interoperability System IST Rev. 4.6	
Software requirements (local)		SAMSON SSP interface and serial interface adapter TROVIS-VIEW with database module 3730-5	
Permissible operating voltage		9 to 32 V DC · Power over bus line The limits in the EC Type Examination Certificate additionally apply for explosion-protected devices.	
Maximum operating current		15 mA	
Additional current in case of error		0 mA	
Supply air	Supply air Air quality	1.4 to 6 bar (20 to 90 psi) Acc. to ISO 8573-1 (2001): Max. particle size and density: Class 4 · Oil content: Class 3 Pressure dew point: Class 3 or at least 10 K below the lowest ambient temperature to be expected	
Signal pressure (output)		0 bar up to capacity of the supply pressure	
Characteristics		Linear/equal percentage/reverse equal percentage · User-defined (over operating software and communication) · Butterfly valve linear/equal percentage · Rotary plug valve linear/equal percentage · Segmented ball valve linear/equal percentage Deviation from characteristic ≤ 1 %	
Hysteresis		≤ 0.3 %	
Sensitivity		≤ 0.1 %	
Direction of action		Reversible	
Air consumption		Independent of supply air <110 l _n /h	
Air output capacity	Actuator pressurized	At Δp = 6 bar: ≥ 8.5 m _n ³ /h · At Δp = 1.4 bar: 3.0 m _n ³ /h · K _{Vmax(20 °C)} = 0.09	
	Actuator vented	At Δp = 6 bar: ≤ 14.0 m _n ³ /h · At Δp = 1.4 bar: 4.5 m _n ³ /h · K _{Vmax(20 °C)} = 0.15	
Perm. ambient temperature		-40 to +80 °C The limits in the EC Type Examination Certificate additionally apply for explosion-protected devices.	
Influences	Temperature	≤ 0.15 %/10 K	
	Supply air	None	
	Vibrations	≤ 0.25 % up to 2000 Hz and 4 g acc. to IEC 770	
Electrical connections		One M20x1.5 cable gland for 6 to 12 mm clamping range · Second M20x1.5 threaded connection additionally exists · Screw terminals for 0.2 to 2.5 mm ² wire cross-sections	
Electromagnetic compatibility		Conforming to requirements in EN 61000-6-2, 61000-6-3 and NAMUR Recommendation NE 21	
Degree of protection		IP 66 / NEMA 4X	
Implementation in safety-relevant systems in compliance with IEC 61508/SIL		Probability of failure on demand of safety functions PFD < 2.8 x 10 ⁻⁷ for a confidence level of 95 %. The safe failure fraction (SFF) according to Table A1 in IEC 61508-2 is greater or equal to 0.99. Suitable for implementation in safety-relevant systems with a hardware fault tolerance of 1 or 2 up to and including SIL 4.	
Binary input 1			
Input		0 to 30 V DC with reverse polarity protection · Static destruction limit 40 V Current consumption 3.5 mA at 24 V, galvanically isolated	
Signal		Signal "1" at U _e > 5 V	Signal "0" at U _e < 3 V
Materials			
Housing		Die-cast aluminum EN AC-43400 / DIN EN 1706 · Chromated and powder paint coated Special version in stainless steel 1.4581	
External parts		Stainless steel 1.4571 and 1.4301	
Cable gland		Nickel-plated brass, M20 x 1.5	
Weight		Approx. 1.0 kg	
Options for Type 3730-5			
Binary input 2 for floating contact			
Switching input		R < 100 Ω · Contact load 100 mA · Static destruction limit 20 V / 5.8 mA · Galvanically isolated	

Dimensions in mm

Direct attachment

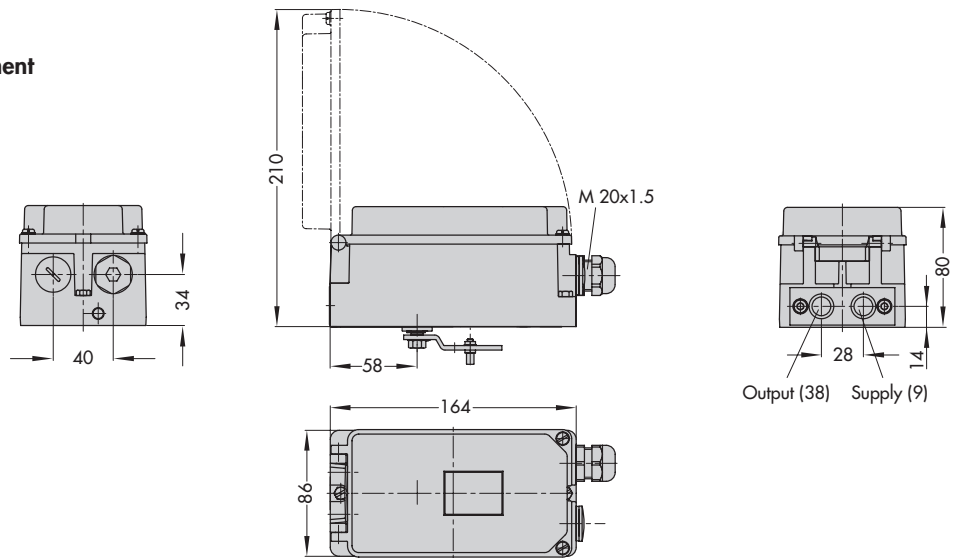

NAMUR attachment

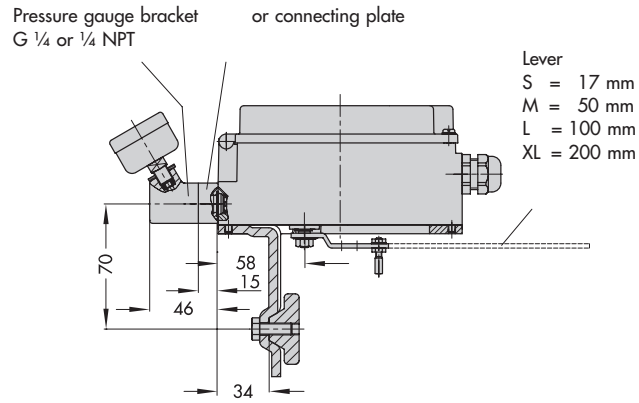

Attachment to rotary actuators

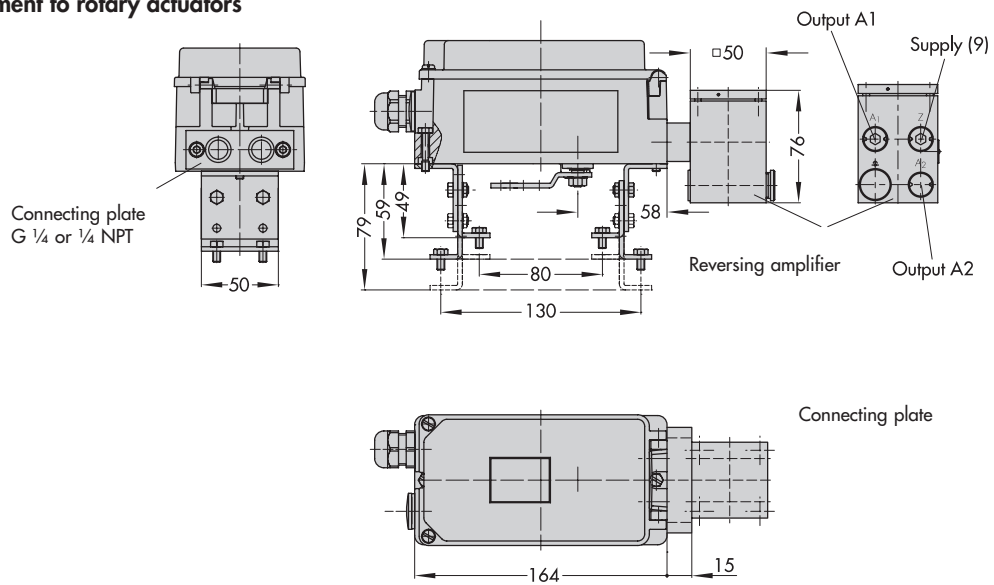

Article code

Positioner	Type 3730-	5	x	x	x	0	x	0	x	x	0	x	0	0	x	0	x	x	
With LCD and autotune, FOUNDATION™ Fieldbus																			
Explosion protection																			
Without		0																	
⊕ II 2 G EEx ia IIC T6 and ⊕ II 2 D IP 65 T 80 °C acc. to ATEX		1																	
CSA/FM intrinsically safe/non incandive; Ex ia/Ex nA		3																	
⊕ II 3 G EEx nA II T6 / EEx nL IIC T6																			
⊕ II 3 D IP 65 T 80 °C acc. to ATEX		8																	
Additional equipment																			
Inductive limit switch																			
Without		0																	
1 x Type SJ2-SN		1																	
Solenoid valve																			
Without				0															
With, 24 V DC				4															
External position sensor																			
Without						0													
With						1													
Binary input																			
Without								0											
Floating contact								1											
Diagnostics																			
EXPERT (standard)									1										
EXPERT+ (extended diagnostics)									2										
Housing material																			
Aluminum (standard)											0								
Stainless steel 1.4581											1								
Special application																			
Without																	0		
Device free of any substances that might impair paint adhesion																	1		
Exhaust air connection with 1/4-18 NPT thread																	2		
Special version																			
None																	0	0	0
NEPSI Ex ia																	0	0	9
NEPSI Ex nl																	0	1	0

Ordering text

FOUNDATION™ Fieldbus Positioner Type 3730-5

- SAMSON direct attachment
- Attachment according to NAMUR
- Attachment to rotary actuator
- Without/with pressure gauge to monitor the signal pressure
- Explosion protection
- Limit switch
- Solenoid valve
- Binary input for floating contact
- Extended EXPERT+ diagnostics

Specifications subject to change without notice.



SAMSON AG · MESS- UND REGELTECHNIK
 Weismüllerstraße 3 · 60314 Frankfurt am Main · Germany
 Phone: +49 69 4009-0 · Fax: +49 69 4009-1507
 Internet: <http://www.samson.de>

T 8384-5 EN

2006-04